

# VacuFil Compact

Art. No.: 82 360



## Technical Data

Filter	
Filter stages	1
Filter method	Cleanable filter
Filter cleaning method	Rotating nozzle
Filter surface	6.7 m <sup>2</sup>
Type of filter	Filter cartridge
Filter material	ePTFE membrane
Filter efficiency	> 99,9 %
Dust classification	M
Basic data	
Max. extraction capacity	160 m <sup>3</sup> /h
Extraction performance at 18000 Pa	50 m <sup>3</sup> /h
Maximum vacuum	24000 Pa
Dimensions (w x t x h)	589 x 590.5 x 833 mm
Weight	65 kg
Motor power	1.5 kW
Power supply	1 x 230 V / 50 Hz
Rated current	13 A
Additional information	
IFA-Certification	IFA W3 EN ISO 21904-1 - Under examination
Fan type	Side channel blower
Hose connection	Ø 45 mm
Air outlet	63 mm

## Applications

- High levels of smoke and particles
- Non-stop operation
- Torch extraction
- Alternating work places

## Benefits

- Stepless preselection of the extraction power for the use of various extraction torches
- Intuitive one-button operation, for use with gloves
- Outstanding price-performance ratio thanks to a wide range of additional features
- High extraction capacity by means of side channel blower
- Well suited for changing workplaces due to compact design

## Properties

- Button activated filter cleaning
- Side channel blower
- Intuitive one-button operation
- Stepless air volume selection
- USB Type-A charging socket
- Compact design
- Monitoring of the extraction rate

## Accessories

- Automatic start-stop
- Automatic air volume control
- Tool tray with cup holder
- Suction hose
- Slot and funnel nozzle
- Connector for welding torches

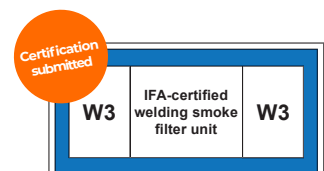

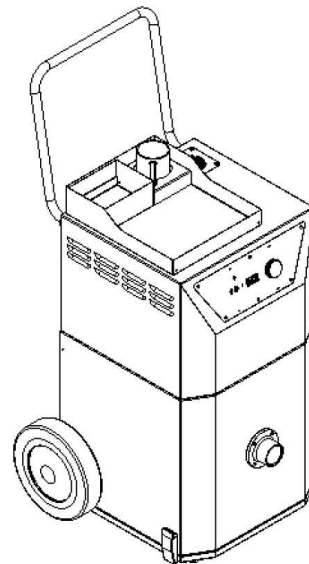
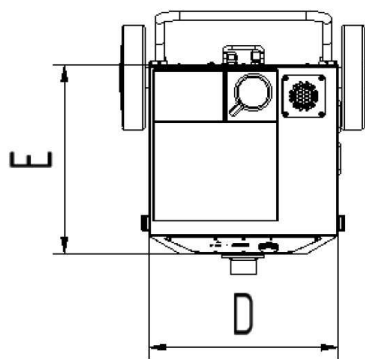
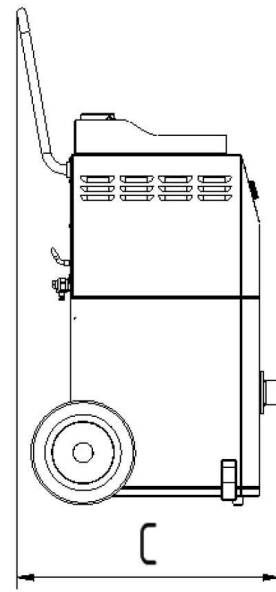
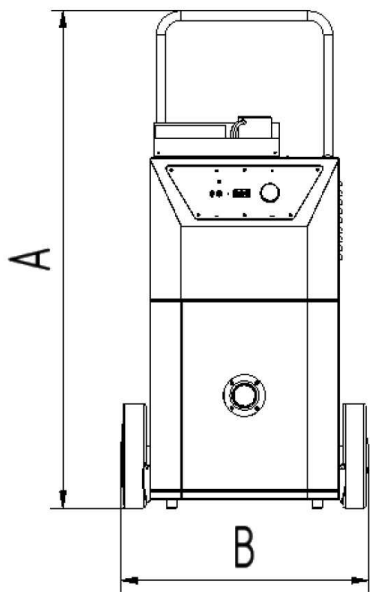

## Technical Data

### Dimensions

A	1191 mm
B	589 mm
C	625 mm
D	450 mm
E	450 mm